

Type	: Rechargeable Nickel Metal Hydride Cylindrical Cell
Nominal Dimension (with Sleeve)	: $\Phi = 14.5\text{mm}$ H = 50.5mm
Applications	: Recommended discharge current 250 to 7500mA
Nominal Voltage	: 1.2V
Capacity	: Nominal: 2500mAh Minimum: 2500mAh Typical: 2600mAh When discharged at 500mA to 1.0V at 20°C
Charging Condition	: 250mA for 16 hrs at 20°C
Fast Charge	: 1250mA to 2500mA (0.5 to 1C) charge termination control recommended control parameters: - ΔV : 0-5mV DT/dt : 0.8°C/min (0.5 to 0.9C) 0.8 - 1°C/min (1C) TCO : 45 - 50°C Timer : 100% nominal input (for ref. only)
Service Life	: >500 cycles (IEC standard)
Continuous Overcharge	: 250mA maximum current for 1 year. No conspicuous deformation and/or leakage
Weight	: 31.5g
Internal Resistance	: Average 18m Ω upon fully charged (Range 14 - 28m Ω) at 1000Hz
Max. Charging Voltage	: 1.5V at 250mA charging
Ambient Temperature Range	: Standard Charge : 0 to 45°C Fast Charging : 10 to 45°C Discharge : -20 to 50°C Storage : -20 to 35°C

Model No.:

270AAHC

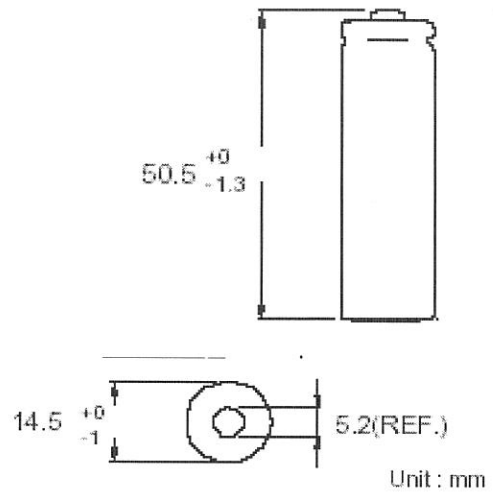

Low Rate Discharge

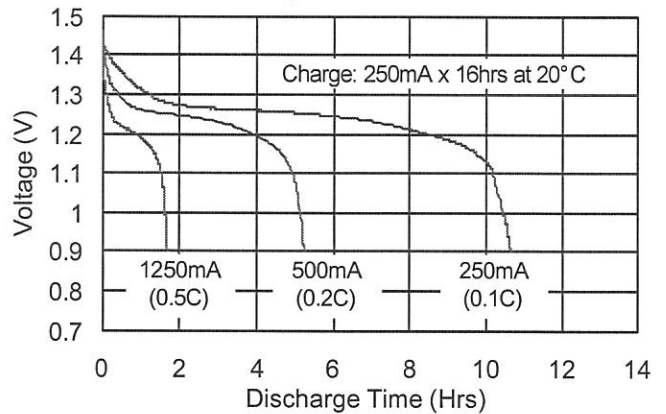

High Rate Discharge

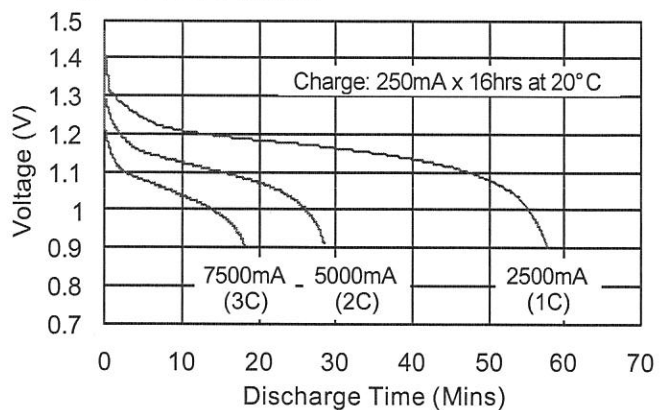

Fast Charge (Charge Control Required)

