

Specification for LiFeS2

Title	Model	Description	Page																																						
Product Specification	LFB AA	Lithium/Iron Disulfide (Li/FeS2)	1																																						
<p>1. Preface</p> <p>The purpose of this product specification is to provide technical information for the Lithium/Iron Disulfide (Li/FeS2) Lithium battery LFB AA, manufactured and supplied by Great Power battery Co., Ltd.</p>																																									
<p>2. Description and Model</p> <table style="width: 100%; border-collapse: collapse;"> <tr> <td style="width: 50%;">2.1 Description</td> <td style="width: 50%;">Lithium/Iron Disulfide (Li/FeS2)</td> </tr> <tr> <td>2.2 Model</td> <td>LFB AA</td> </tr> </table>				2.1 Description	Lithium/Iron Disulfide (Li/FeS2)	2.2 Model	LFB AA																																		
2.1 Description	Lithium/Iron Disulfide (Li/FeS2)																																								
2.2 Model	LFB AA																																								
<p>3. Specification</p> <table style="width: 100%; border-collapse: collapse;"> <tr> <td style="width: 50%;">3.1 Rated Capacity</td> <td style="width: 50%;">2900mAh at 1000mA discharge</td> </tr> <tr> <td>3.2 Average Weight</td> <td>14.5g</td> </tr> <tr> <td>3.3 Nominal Voltage</td> <td>1.5V</td> </tr> <tr> <td>3.4 Work Voltage</td> <td>1.30V at Constant current 200mA discharge</td> </tr> <tr> <td>3.5 Cut-off Discharge Voltage</td> <td>0.80V</td> </tr> <tr> <td>3.6 Max.Discharge Current</td> <td>2000mA</td> </tr> <tr> <td>3.7 Volume</td> <td>8.0 cubic centimeters (0.5 cubic inch)</td> </tr> <tr> <td>3.8 Lithium Content</td> <td>Less than 1 gram (0.04 oz.) per cell</td> </tr> <tr> <td>3.9 Ambient Temperature</td> <td></td> </tr> <tr> <td style="padding-left: 20px;">for Standard Charge</td> <td style="text-align: center;">0℃~ 45℃</td> </tr> <tr> <td style="padding-left: 20px;">for Discharge</td> <td style="text-align: center;">-20℃~ 60℃</td> </tr> <tr> <td>3.10 Storage</td> <td></td> </tr> <tr> <td style="padding-left: 20px;">for within the temperature</td> <td style="text-align: center;">-20℃~ 60℃</td> </tr> <tr> <td style="padding-left: 20px;">for within the humidity</td> <td style="text-align: center;">≤75%</td> </tr> <tr> <td>3.11 Energy Density</td> <td></td> </tr> <tr> <td style="padding-left: 20px;">Wh/L</td> <td></td> </tr> <tr> <td style="padding-left: 20px;">Wh/Kg</td> <td></td> </tr> <tr> <td>3.12 Shell Life</td> <td style="text-align: center;">10years</td> </tr> <tr> <td>3.13 Charge State Internal Impedance</td> <td></td> </tr> </table>				3.1 Rated Capacity	2900mAh at 1000mA discharge	3.2 Average Weight	14.5g	3.3 Nominal Voltage	1.5V	3.4 Work Voltage	1.30V at Constant current 200mA discharge	3.5 Cut-off Discharge Voltage	0.80V	3.6 Max.Discharge Current	2000mA	3.7 Volume	8.0 cubic centimeters (0.5 cubic inch)	3.8 Lithium Content	Less than 1 gram (0.04 oz.) per cell	3.9 Ambient Temperature		for Standard Charge	0℃~ 45℃	for Discharge	-20℃~ 60℃	3.10 Storage		for within the temperature	-20℃~ 60℃	for within the humidity	≤75%	3.11 Energy Density		Wh/L		Wh/Kg		3.12 Shell Life	10years	3.13 Charge State Internal Impedance	
3.1 Rated Capacity	2900mAh at 1000mA discharge																																								
3.2 Average Weight	14.5g																																								
3.3 Nominal Voltage	1.5V																																								
3.4 Work Voltage	1.30V at Constant current 200mA discharge																																								
3.5 Cut-off Discharge Voltage	0.80V																																								
3.6 Max.Discharge Current	2000mA																																								
3.7 Volume	8.0 cubic centimeters (0.5 cubic inch)																																								
3.8 Lithium Content	Less than 1 gram (0.04 oz.) per cell																																								
3.9 Ambient Temperature																																									
for Standard Charge	0℃~ 45℃																																								
for Discharge	-20℃~ 60℃																																								
3.10 Storage																																									
for within the temperature	-20℃~ 60℃																																								
for within the humidity	≤75%																																								
3.11 Energy Density																																									
Wh/L																																									
Wh/Kg																																									
3.12 Shell Life	10years																																								
3.13 Charge State Internal Impedance																																									
<p>4. Appearance</p> <p>Appearance shall be free from any remarkable scratch, flaws, rust, discoloration or electrolyte leakage (visible or by smell)</p>																																									
<p>5. Standard Test condition</p> <p>5.1 Environment Conditions</p> <p style="padding-left: 20px;">Unless otherwise specified, all test stated in this Product Specification are conducted within the temperature 15~25℃ and the humidity 45~85%RH.</p>																																									

Specification for LiFeS2

Title	Model	Description	Page
Product Specification	LFB AA	Lithium/Iron Disulfide (Li/FeS2)	2

5.2 Test Equipment

(1) Impedance meter

The impedance meter with AC 1kHz should be used

6. Test Procedure and Its Standard

Item	Measuring Procedure	Standard
6.1 Appearance	Visual	No Defect and Leak
6.2 Dimension	Caliper	As item 8
6.3 Weight	Scale	As item 3.12
6.4 Max. Discharge Current	Until final discharge voltage	2000mA
6.6 Open Circuit Voltage	Within 1hr after full charge, measure Open circuit voltage	>1.72V
6.7 Internal Impedance	Measure the battery with 1kHz AC	
6.8 Discharge Capacity	Within 1hr after full charge, discharge until final discharge, at 0.2C mA and measure the capacity	>2900mAh
6.9 Leakage Proof	After full charging, the battery shall be stored at $40 \pm 2^\circ\text{C}$ and humidity $80 \pm 5\%$ for 21 days	No leakage should be observed by visual inspection

8. Dimension (Bare cell) mm

7. Discharge Curve discharge at 1000mA to 0.8V

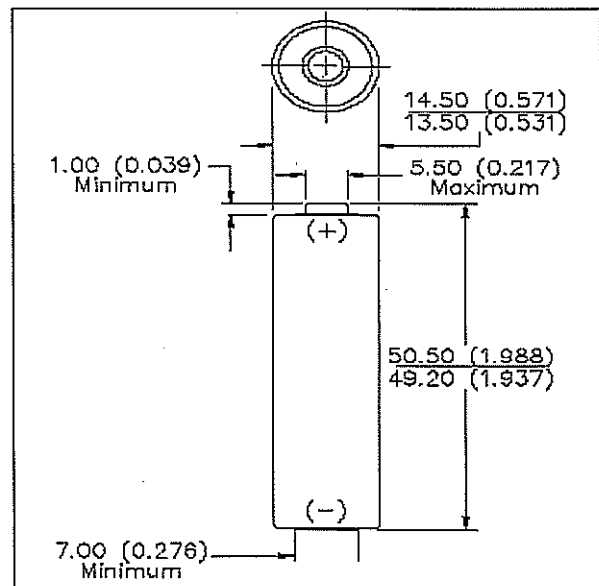
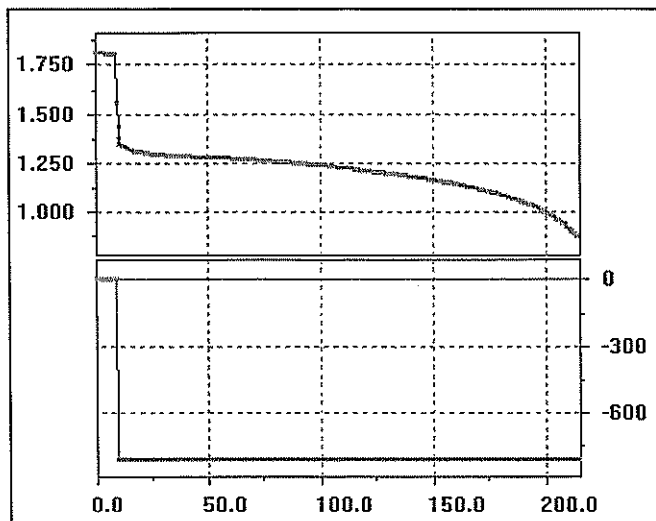

Specification Sheet

1. Model No.: **650420**
2. Product Name: Lithium/Iron Disulfide (Li/FeS₂)
3. Electrical features:
 - 1) Nominal voltage: 1.5V
 - 2) Nominal capacity: 2900mAh at 1000mA discharge
 - 3) Discharge-End-voltage: 0.80V
 - 4) Operating voltage: 1.30V at Constant current 200mA discharge
 - 5) Max discharge current: 2000mA
 - 6) Ambient temperature for Discharge: -20 °C ~60°C
4. Other features
 - 1) Appearance: Cylindrical shape
 - 2) Lithium Content: Less than 1 gram (0.04 oz.) per cell
 - 3) Volume: 8.0 cubic centimeters (0.5 cubic inch)
 - 4) Average weight: 14.5 g
5. Storage
 - 1) Temperature: -20 °C ~60°C
 - 2) Humidity: ≤75%
 - 3) Storage life: 10 years
6. Performance Testing

Examination procedure & standard

1.Appearance Appearance shall be free from any remarkable scratch, flaws, rust, discoloration or electrolyte leakage (visible or by smell)		
2.Standard Test condition 2.1 Environment Conditions Unless otherwise specified, all test stated in this Product Specification are conducted within the temperature 15~25 °C and the humidity 45~85%RH. 2.2 Test Equipment (1) Impedance meter The impedance meter with AC 1kHz should be used		
3.Test Procedure and Its Standard		
Item	Measureing Procedure	Standard
3.1 Appearance	Visual	No Defect and Leak
3.2 Dimension	Caliper	As item 8
3.3 Weight	Scale	As item 3.12
3.4 Max. Discharge Current	Until final discharge voltage	2000mA
3.5 Open Circuit Voltage	Measure open circuit voltage	≥1.72V
3.6 Internal Impedance	Measure the battery with 1kHz AC	

3.7 Discharge Capacity	The battery discharge until final discharge voltage 0.8V, at 0.2C mA and measure the capacity	>2900mAh
3.8 Leakage Proof	The battery shall be stored at 40±2°C and humidity 80±5% for 21 days	No leakage should be observed by visual inspection

4. Discharge Curve discharge to 0.8V 5. Dimension (Bare cell) mm

